

## WBC4030DB36B1P0

### Bottom port digital silicon Microphone

#### Descriptions

WBC4030DB36B1P0 is a Silicon Microphone with digital output and bottom inlet for sound input. It consists of a MEMS sensor and an encoder IC. It converts sensor analog output signal into 1-bit digital PDM data. The digital output format eliminates AC coupling capacitor, reduces RF noise coupling and eases PCB layout requirement.

WBC4030DB36B1P0 is a cost-effective alternative to traditional electret condenser microphone (ECM). Provided on tap-and-reel, it is ideally suited for high volume applications. And it can be processed directly to customer's PCB using standard automatic pick-and-place equipment and surface mounted via standard solder reflow equipment.

WBC4030DB36B1P0 can be used to implement the array microphones. Speech quality can be significantly improved by combining two microphones.

The WBC4030DB36B1P0 is manufactured in a compact 4.00mm\*3.00mm\*1.20mm, 5-pin package.

#### Features

- PDM Output
- High SNR
- Multiple performance modes
- Ultra-Stable Performance
- Standard SMD Reflow
  - RoHS/Halogen free compliant
- Omnidirectional

#### Applications

- Smart phones
- Smart speakers
- Portable communication device
- Notebook and desktop
- Digital still cameras
- Smart home electronics

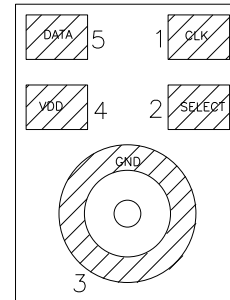

Pin configuration (Bottom view)

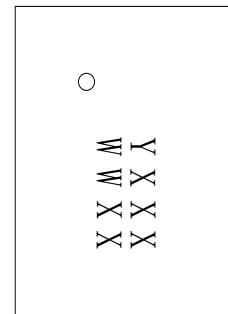

Marking (Top view)

Y = Year code

WW = Week code

XX = Data code

#### Order information

Device	Package(mm)	Shipping
WBC4030DB36B1P0-5/TR	4.00*3.00*1.20	5000/Reel&Tape

## Absolute Maximum Ratings

Parameter		Maximum Ratings	Unit
Supply voltage		3.6	V
Voltage on any pin		3.6	V
Operation temperature range	VDD < 3V	-40~100	°C
	VDD > 3V	-40~70	°C
Storage temperature range		-40~125	°C

Stresses at the maximum ratings shown in Table 1 may cause permanent damage to the device. These are stress ratings only at which the device may not function when an operation at these or any other condition beyond those specified under “Electro-Acoustic Specifications”.

## Acoustic & Electrical Specifications

### Normal Mode Electrical Specifications

Test condition: +25±2°C, 60%~70% RH, 86~106Kpa, F<sub>CLK</sub>=3.072MHz, V<sub>DD</sub>=1.8V, no load, unless otherwise noted.

Symbol	Description	Min.	Typ.	Max.	Units
F <sub>CLK</sub>	Clock Frequency	1.38	3.072	3.3	MHz
I <sub>DD</sub>	Supply Current <sup>1</sup>		1000	1300	μA
S	Sensitivity <sup>3</sup> , 94dB SPL@1KHz	-37	-36	-35	dBFS <sup>2</sup>
SNR	100-10KHz Bandwidth, A-weighted		70		dB(A)
	20-20KHz Bandwidth, A-weighted	67	69		dB(A)
THD	94dB SPL@1KHz		0.03	0.5	%
	121dB SPL@1KHz		1		%
AOP	10%THD@1KHz		132		dB SPL
PSR	Measured with 217Hz, 100mVpp square wave		-112	-95	dBFS

### Low Power Mode Electrical Specifications

Test condition: +25±2°C, 60%~70% RH, 86~106Kpa, F<sub>CLK</sub>=768KHz, V<sub>DD</sub>=1.8V, no load, unless otherwise noted.

Symbol	Description	Min.	Typ.	Max.	Units
--------	-------------	------	------	------	-------

FCLK	Clock Frequency	450	768	850	KHz
I <sub>DD</sub>	Supply Current		300	380	uA
S	Sensitivity,94dB SPL@1KHz	-37	-36	-35	dBFS
SNR	20-8KHz Bandwidth, A-weighted		65		dB(A)
THD	94dB SPL@1KHz		0.20	0.5	%
	127dB SPL@1KHz		1		%
AOP	10%THD@1KHz		132		dB SPL
PSR	Measured with 217Hz,100mVpp square wave		-112	-95	dBFS

Note 1: The current consumption depends on the applied clock frequency and the load on the DATA output

Note 2: dBFS=20\*logA/B, where A is the level of signal, and B is the level that corresponds to full-scale level

Note 3: Relative to the rms level of a sine wave with positive amplitude equal to 100% 1s density and  
Negative amplitude equal to 0% 1s density

Note 4: Frequency response, sensitivity and current consumption are tested by 100% on product line.

### General Electrical Specifications

Test condition: +25±2°C, 60%~70% RH, 86~106Kpa, no load, unless otherwise noted.

Symbol	Description	Min.	Typ.	Max.	Units	
V <sub>DD</sub>	Supply Voltage	1.62	1.8	3.6	V	
F <sub>CLK</sub>	Clock Frequency (Mode switch clock tolerance +/-5%)	Standby Mode		330	KHz	
		Low Power Mode	450	768	850	KHz
		Normal Mode	1.38	3.072	3.3	MHz
Data Format		1/2 Cycle PDM				
Directivity		Omni-directional				
Polarity		Increasing density of 1's				
I <sub>clock_off</sub>	Clock off mode, Clock pulled low		1		uA	
I <sub>standby</sub>	Standby mode, Clock<330KHz			50	uA	
I <sub>SC</sub>	Short circuit current ,Grounded DATA pin	1		20	mA	
C <sub>LOAD</sub>	Load capacitance			150	pF	
Startup Time	Time to start up in either modes (Low Power- and Normal Mode)			20	ms	
Reset Time	Time to start up in either modes (Low Power- and Normal Mode) after VDD has been off for more than 10ms, while CLOCK remained on.			20	ms	
Mode-Switch Time	Time to switch between modes (Clock Off-, Low Power-, and Normal Mode). VDD remains on during the mode switch.			20	ms	

## Microphone State Diagram

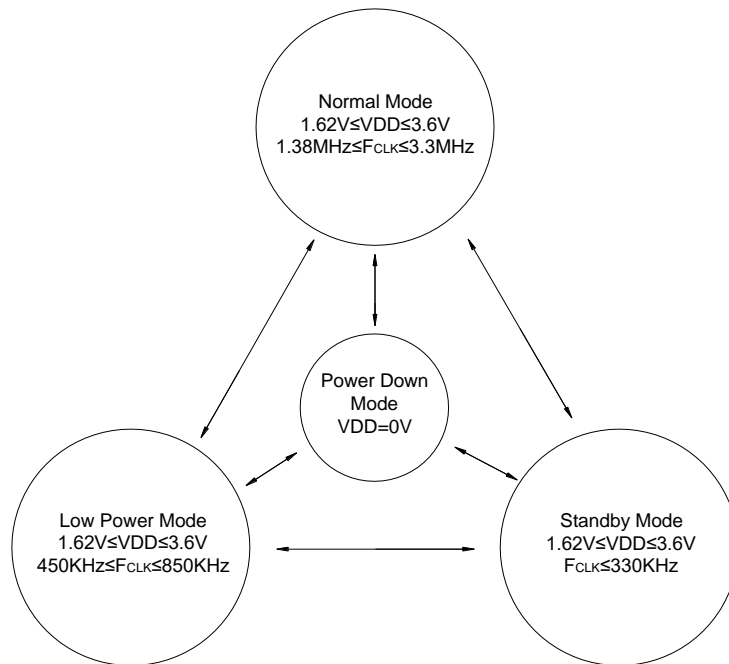

## Frequency Response Curve

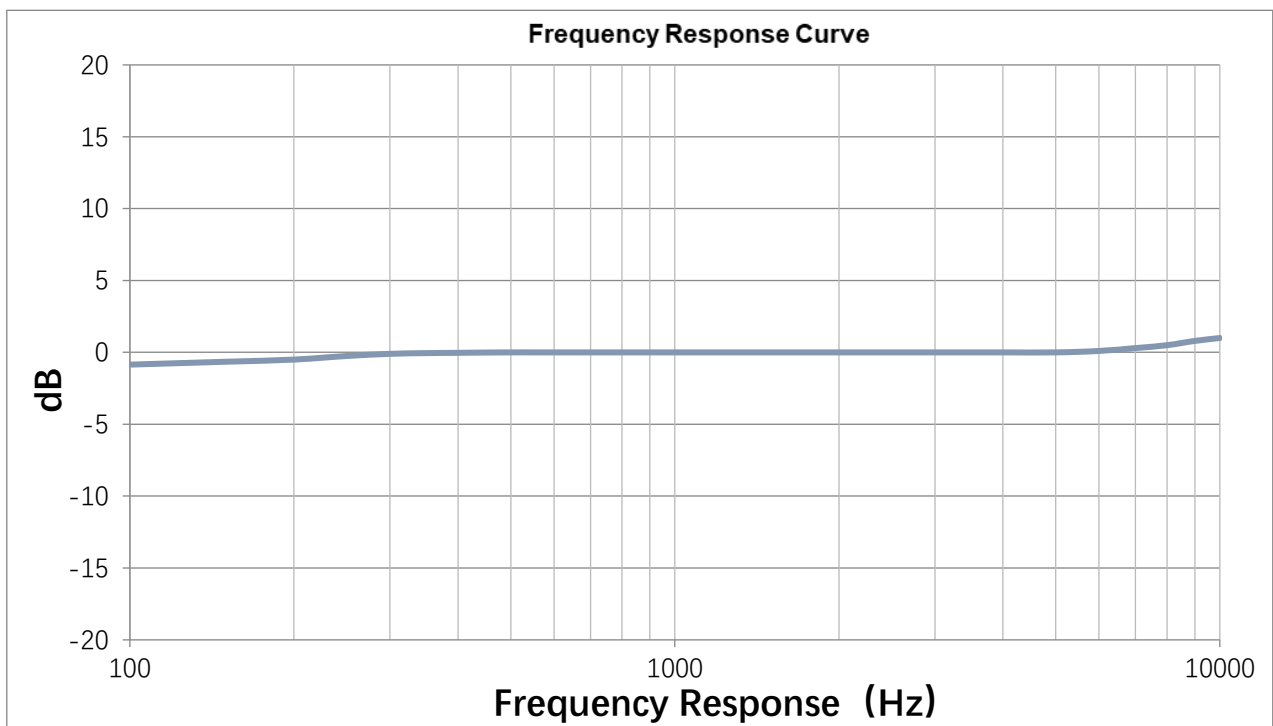

## Application Information

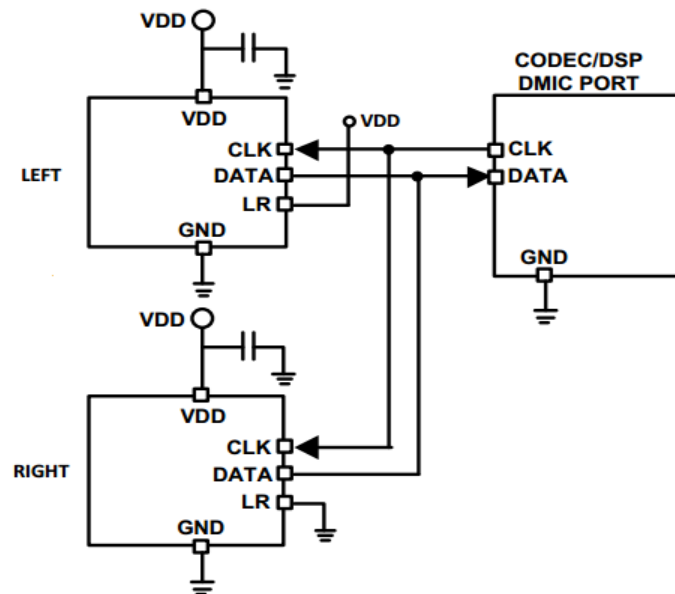

Microphone	SELECT	Asserts DATA On	Latch DATA On
Mic (High)	V <sub>DD</sub>	Rising Clock Edge	Falling Clock Edge
Mic (Low)	GND	Falling Clock Edge	Rising Clock Edge

Note:

- All GND pins must be connected to ground.
- Capacitors near the microphone should not contain Class 2 dielectrics.

## Clock Timing Diagram

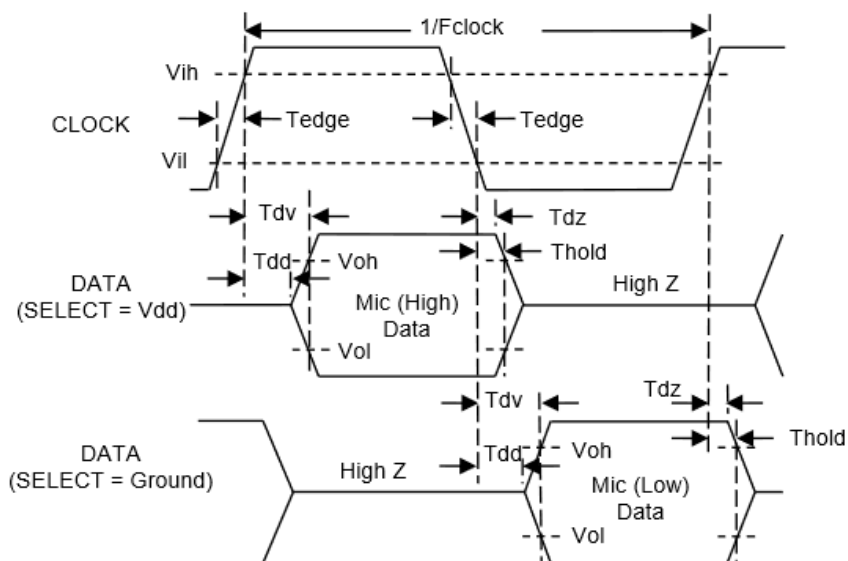

## Timing Characteristics

Parameter	Symbol	Min.	Typ.	Max.	Unit	Note
Clock duty cycle		45		55	%	$f_{\text{clock}} < 2.65\text{MHz}$
		48		52	%	$f_{\text{clock}} \geq 2.9\text{MHz}$
Operation Voltage	$V_{\text{DD}}$	1.62		3.6	V	
Input Logic Low Level	$V_{\text{IL}}$	-0.3		$0.35 \times V_{\text{DD}}$	V	
Input Logic High Level	$V_{\text{IH}}$	$0.65 \times V_{\text{DD}}$		$V_{\text{DD}} + 0.3$	V	
Hysteresis width	$V_{\text{hys}}$	$0.05 \times V_{\text{DD}}$				
Output Logic Low Level	$V_{\text{OL}}$			$0.3 \times V_{\text{DD}}$	V	
Output Logic High Level	$V_{\text{OH}}$	$0.7 \times V_{\text{DD}}$			V	
Clock rise time	$t_{\text{CR}}$			13	ns	
Clock fall time	$t_{\text{CF}}$			13	ns	
Delay time for DATA driven	$t_{\text{DD}}$	40		80	ns	
Delay time for data valid	$t_{\text{DV}}$			100	ns	
Delay time for data high Z	$t_{\text{DH}}$	5		30	ns	

## Mechanical Specifications

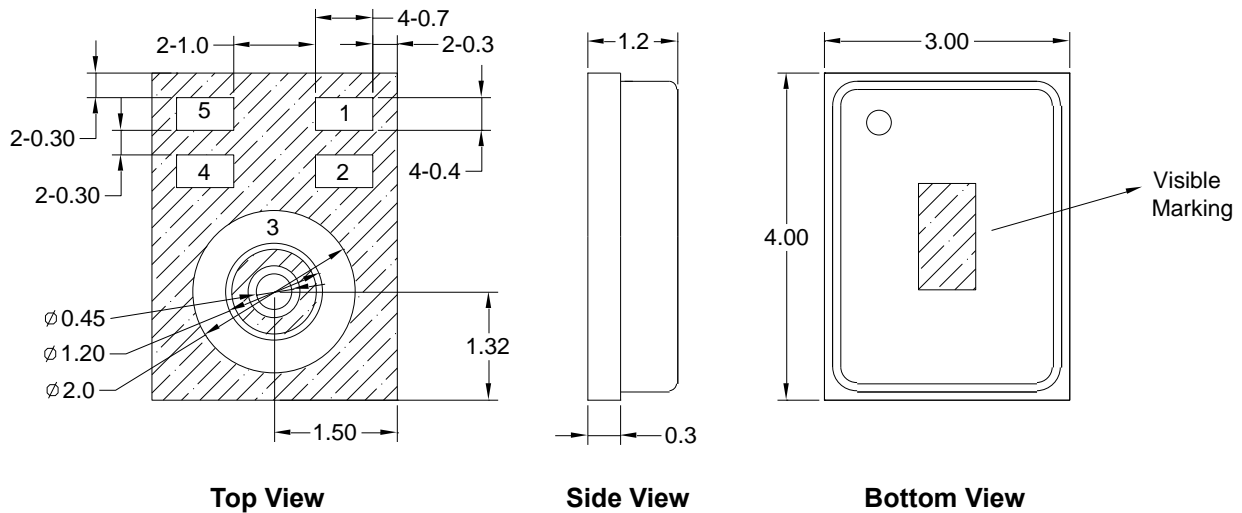

Item	Dimension	Tolerance
Length(L)	4.00	$\pm 0.10$
Width(W)	3.00	$\pm 0.10$
Height(H)	1.20	$\pm 0.10$
Acoustic Port (AP)	$\varnothing 0.45$	$\pm 0.05$

Pin#	Pin Name	Description
1	CLK	Clock input
2	L/R	L/R select (No internal pull-down. Must be connected to VDD or GND)
3	GND	Ground
4	VDD	Power Supply
5	DATA	PDM Output

### Notes:

- Dimensions are in millimeters unless otherwise specified.
- Tolerance is  $\pm 0.10$ mm unless otherwise specified.
- Pick Area only extends to 0.25 mm of any edge or hole unless otherwise specified.
- Suggestion to use the same date code microphone in one array microphone module.

### Packaging & Marking Detail

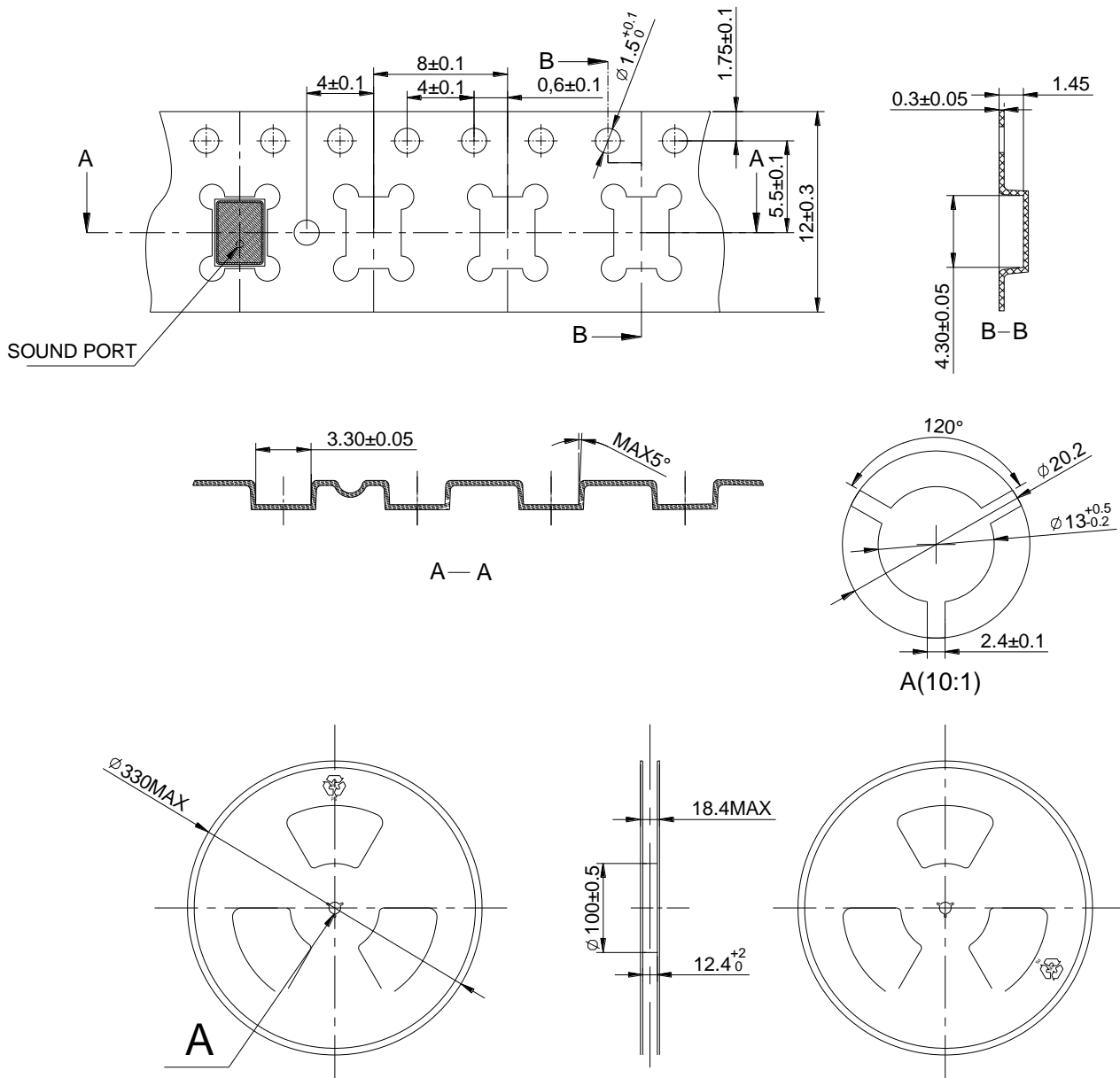

Model Number	Reel Diameter	Quantity Per Reel
WBC4030DB36B1P0	13"	4500

**Notes:**

- Dimensions are in millimeters unless otherwise specified.
- Vacuum pickup only in the pick area indicated in Mechanical Specifications.
- Tape & reel per EIA-481.
- Labels applied directly to reel and external package.



## Referenced Reflow Profile

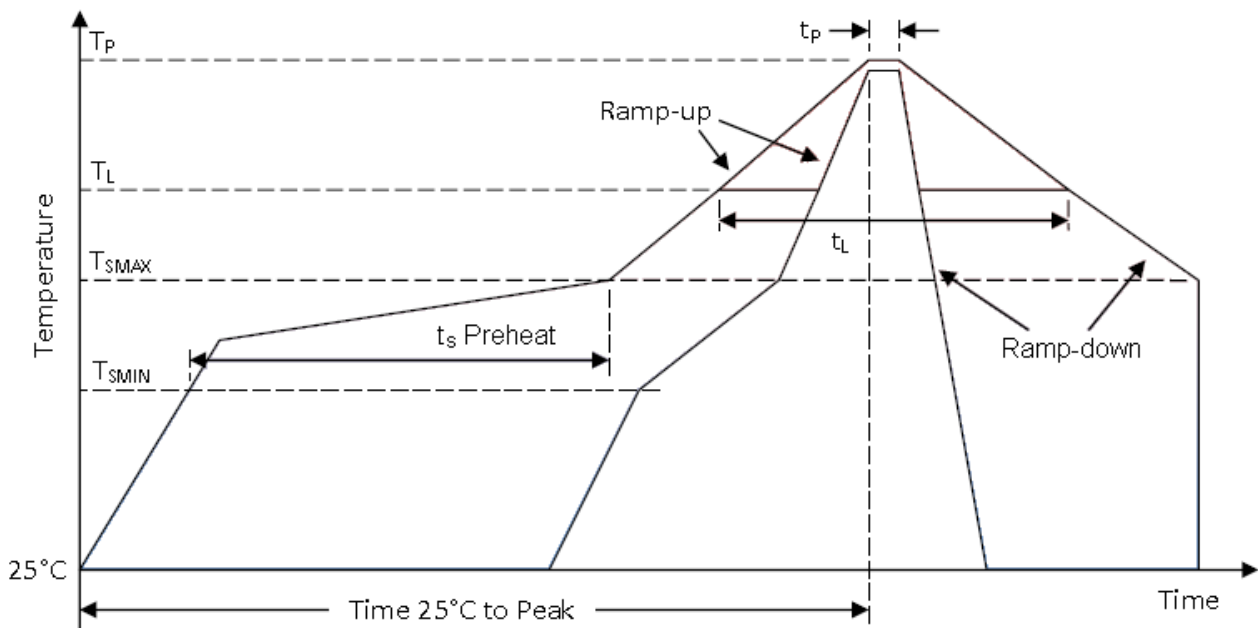

Profile Feature	Pb-Free
Average Ramp-up rate ( $T_{SMAX}$ to $T_P$ )	3°C/second max.
Preheat <ul style="list-style-type: none"> <li>• Temperature Min (<math>T_{SMIN}</math>)</li> <li>• Temperature Max (<math>T_{SMAX}</math>)</li> <li>• Time (<math>T_{SMIN}</math> to <math>T_{SMAX}</math>) (<math>t_s</math>)</li> </ul>	150°C 200°C 60-180 seconds
Time maintained above: <ul style="list-style-type: none"> <li>• Temperature (<math>T_L</math>)</li> <li>• Time (<math>t_L</math>)</li> </ul>	217°C 60-150 seconds
Peak Temperature ( $T_P$ )	260°C
Time within 5°C of actual Peak Temperature ( $t_p$ )	20-40 seconds
Ramp-down rate ( $T_P$ to $T_{SMAX}$ )	6°C/second max
Time 25°C to Peak Temperature	8 minutes max

Note:

All temperatures refer to topside of the package, measured on the package body surface.

## Additional Notes

(A) Maximum of 3 reflow cycles is recommended.

(B) In order to minimize device damage:

- Do not board wash or clean after the reflow process.
- Do not brush board with or without solvents after the reflow process.
- Do not directly expose to ultrasonic processing, welding, or cleaning.
- Do not insert any object in port hole of device at any time.
- Do not apply over 30 psi of air pressure into the port hole.
- Do not pull a vacuum over port hole of the microphone.
- Do not apply a vacuum when repacking into sealed bags at a rate faster than 0.5 atm/sec.

## Materials Statement

Meets the requirements of the European RoHS and Halogen-Free.

## Reliability Specifications

Test	Description
Thermal Shock	100 cycles air-to-air thermal shock from -40°C to +125°C with 15 minute soaks. (IEC 68-2-4)
High Temperature Storage	1000 hours at +105°C environment. (IEC 68-2-2 Test Ba)
Low Temperature Storage	1000 hours at -40°C environment. (IEC 68-2-2 Test Aa)
High Temperature Bias	1000 hours at +105°C under bias. (IEC 68-2-2 Test Ba)
Low Temperature Bias	1000 hours at -40°C under bias. (IEC 68-2-2 Test Aa)
Temperature / Humidity Bias	1000 hours at +85°C /85% R.H. under bias. (JESD22-A101A-B)
Vibration	4 cycles of 20 to 2,000 Hz sinusoidal sweep with 20g peak acceleration lasting 12 minutes in X, Y, and Z directions. (Mil-Std-883E, method 2007.2 A)
ESD-HBM	3 discharges of ±3.5kV direct contact to I/O pins. (ESD STM5.2)
ESD-LID/GND	3 discharges of ±8 kV direct contact to lid while unit is grounded. (IEC 61000-4-2)
ESD-MM	3 discharges of ±200V direct contact to I/O pins. (ESD STM5.2)
Reflow	5 reflow cycles with peak temperature of +260°C.
Mechanical Shock	3 pulses of 10000g in the X, Y, and Z direction. (IEC 68-2-27, Test Ea)
Drop Test	To be no interference in operation after dropped to marble or 1.0cm steel plate 18 times from 1.5 meter height.

Note:

After reliability tests are performed, the sensitivity of the microphones shall not deviate more than 3 dB from its initial value. (The measurement to be done after 2 hours of conditioning at 20±2 °C, R.H 60%~70%)