

WBC4030AB38B1A10

Bottom port analog silicon Microphone

Descriptions

The WBC4030AB38B1A10 is a miniature, high performance, low power, differential output bottom port silicon microphone.

The WBC4030AB38B1A10 consists of a low noise level ASIC, and a dual back-plate MEMS sensor.

These devices are suitable for portable electronic devices where excellent wideband audio performance and RF immunity are required applications.

The WBC4030AB38B1A10 is manufactured in a compact 4.00mm*3.00mm*1.20mm, 4-pin package.

Features

- Matched Sensitivity
- Differential Output
- High SNR
- High AOP
- Flat Frequency Response
- MaxRF protection
- Ultra-Stable Performance
- Standard SMD Reflow
- Omnidirectional

Applications

- Cellphones
- Smart phones
- Laptop computers
- Wearable Electronics
- Digital still cameras
- Portable music recorders
- Smart Home Electronics

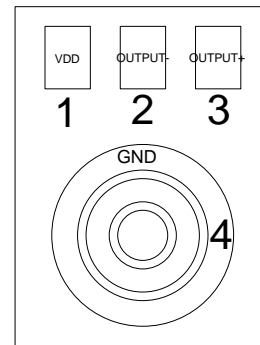

Pin configuration (Bottom view)

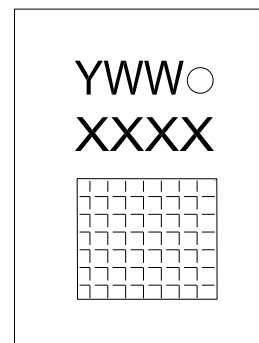

Marking (Top view)

Y = Year code

WW = Week code

X X X X = Batch code

Order information

Device	Package	Shipping
WBC4030AB38B1A10-5/T	4.00*3.00*1.20	4500/Reel&Tape

Absolute Maximum Ratings

Parameter	Absolute Maximum Rating	Units
Supply voltage	3	V
Supply current	2	mA
Output current	1	mA
Operation temperature range	-40~100	°C
Storage temperature range	-40~100	°C

Stresses at the maximum ratings shown in Table 1 may cause permanent damage to the device. These are stress ratings only at which the device may not function when an operation at these or any other condition beyond those specified under “Electro-Acoustic Specifications”.

Acoustic & Electrical Specifications

Normal Mode Electrical Specifications

Test condition: +25±2 °C, 60%~70% RH, 86~106Kpa, Vdd=2.75V, no load, unless otherwise specified.

Parameter	Symbol	Condition	Min.	Nom.	Max.	Unit
Sensitivity	S	f=1kHz, Pin=1Pa, 0dB=1V/Pa	-39	-38	-37	dB
Operating Voltage	VDD		2.3	2.75	3	V
Directivity			Omni-directional			
Polarity		Sound pressure increase	Output voltage increase			
Sensitivity vs. Voltage	ΔS	Vs= 3V to 2.3V	<0.5			dB
Output Impedance	ZOUT	f=1kHz			400	Ω
Current Consumption	I	2.3 V to 3V		170	250	μA
S/N Ratio	S/N	100-10KHz, f=1kHz, Pin=1Pa, A-Weighted		70		dB
		20-20KHz, f=1kHz, Pin=1Pa, A-Weighted	67	69		dB
Total Harmonic Distortion	THD	94dB SPL @1KHz		0.1	0.5	%
		134dB SPL @1KHz		1		
Acoustic Overload Point	AOP	THD 10% @1KHz		137		dB SPL
Power Supply Rejection	PSR	100mVpp Squarewave @217Hz, A-weighted		-110	-100	dB
Power Supply Rejection Ratio	PSRR	200mVpp Sinewave @1KHz	90	100		dB
DC output	VDC			1.30		V
Output load	Cload				150	pF
	Rload		25			K Ω

Note: Frequency response, sensitivity and current consumption are tested by 100% on product line.

Low Power Mode Electrical Specifications

Test condition: +25±2°C, 60%~70% RH, 86~106Kpa, Vdd=1.7V, no load, unless otherwise specified.

Parameter	Symbol	Condition	Min.	Nom.	Max.	Unit
Sensitivity	S	f=1kHz, Pin=1Pa, 0dB=1V/Pa	-39	-38	-37	dB
Operating Voltage	V _{DD}		1.52	1.7	1.9	V
Directivity			Omni-directional			
Polarity		Sound pressure increase	Output voltage increase			
Sensitivity vs. Voltage	ΔS	Vs= 1.9V to 1.52V	<0.5			dB
Output Impedance	Z _{OUT}	f=1kHz			400	Ω
Current Consumption	I	1.52 V to 1.9V		60	80	μA
S/N Ratio	S/N	100-10KHz, f=1kHz, Pin=1Pa, A-Weighted		69		dBA
		20-20KHz, f=1kHz, Pin=1Pa, A-Weighted	66	68		dBA
Total Harmonic Distortion	THD	94dB SPL @1KHz		0.1	0.5	%
		124dB SPL @1KHz		1		
Acoustic Overload Point	AOP	THD 10% @1KHz		132		dB SPL
Power Supply Rejection	PSR	100mVpp Squarewave @217Hz, A-weighted		-110	-100	dB
Power Supply Rejection Ratio	PSRR	200mVpp Sinewave @1KHz	90	100		dB
DC output	VDC			0.9		V
Output load	C _{load}				150	pF
	R _{load}		25			KΩ

Note: Frequency response, sensitivity and current consumption are tested by 100% on product line.

Frequency Response Curve

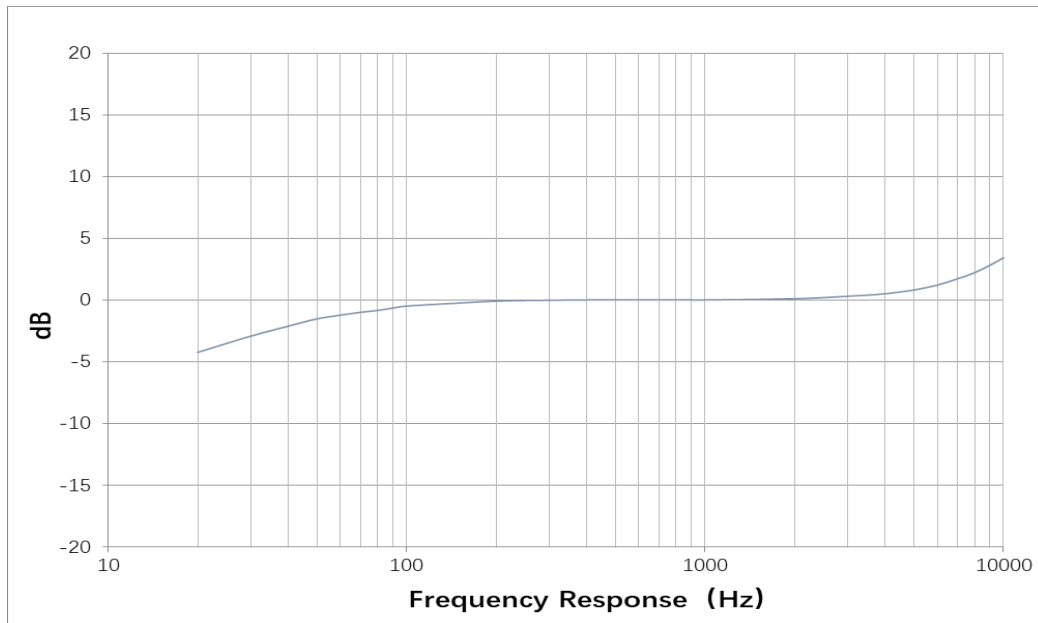

Application Information

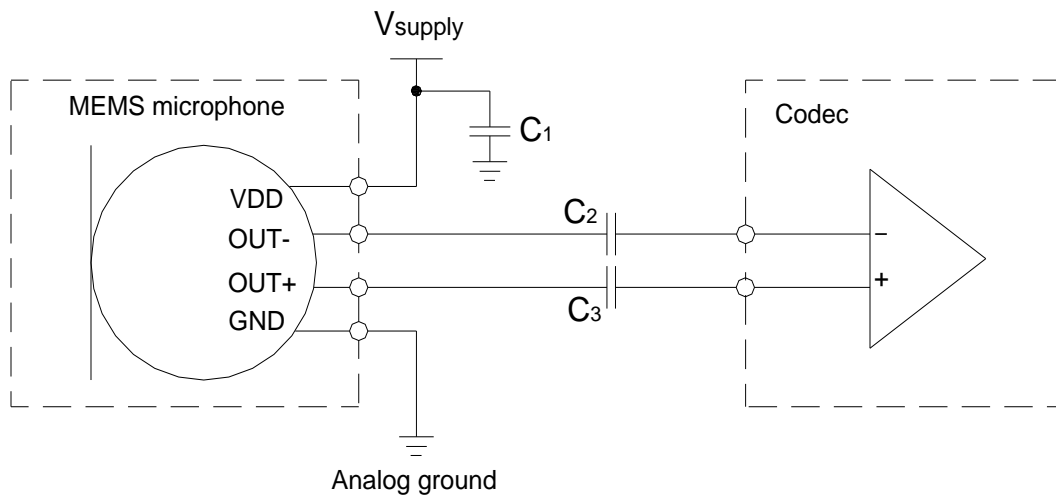

Note:

- All GND pins must be connected to ground.
- Capacitors near the microphone should not contain Class 2 dielectrics.

Mechanical Specification

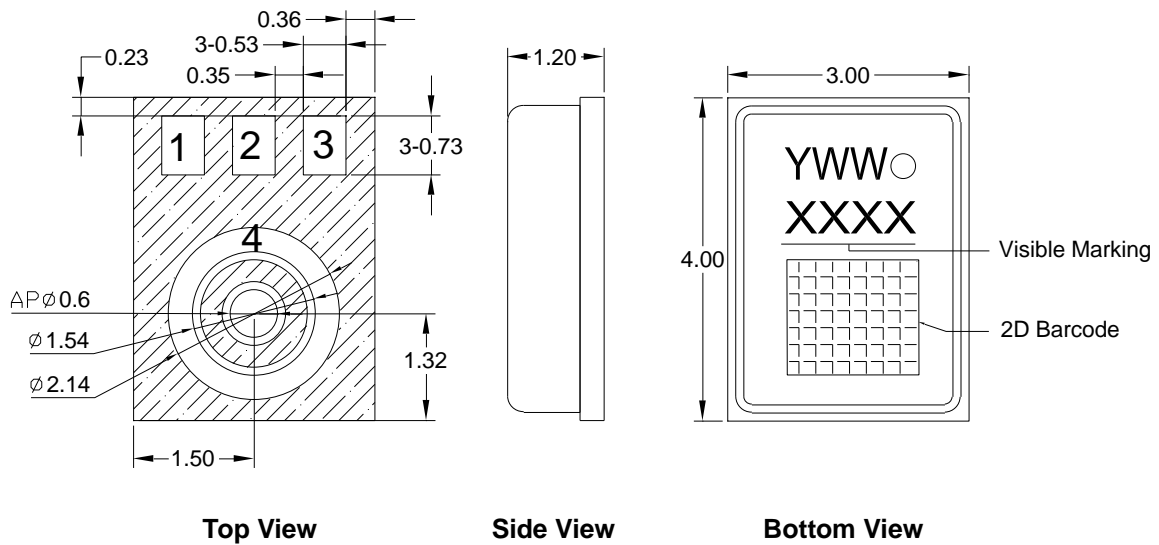

Item	Dimension	Tolerance
Length(L)	4.00	±0.10
Width(W)	3.00	±0.10
Height(H)	1.20	±0.10
Acoustic Port (AP)	Ø0.60	±0.05

Pin#	Pin Name	Description
1	VDD	Power Supply
2	Output-	Negative Output
3	Output+	Positive Output
4	GND	Ground

Notes:

- Dimensions are in millimeters unless otherwise specified.
- Tolerance is ±0.10mm unless otherwise specified.

Packaging & Marking Detail

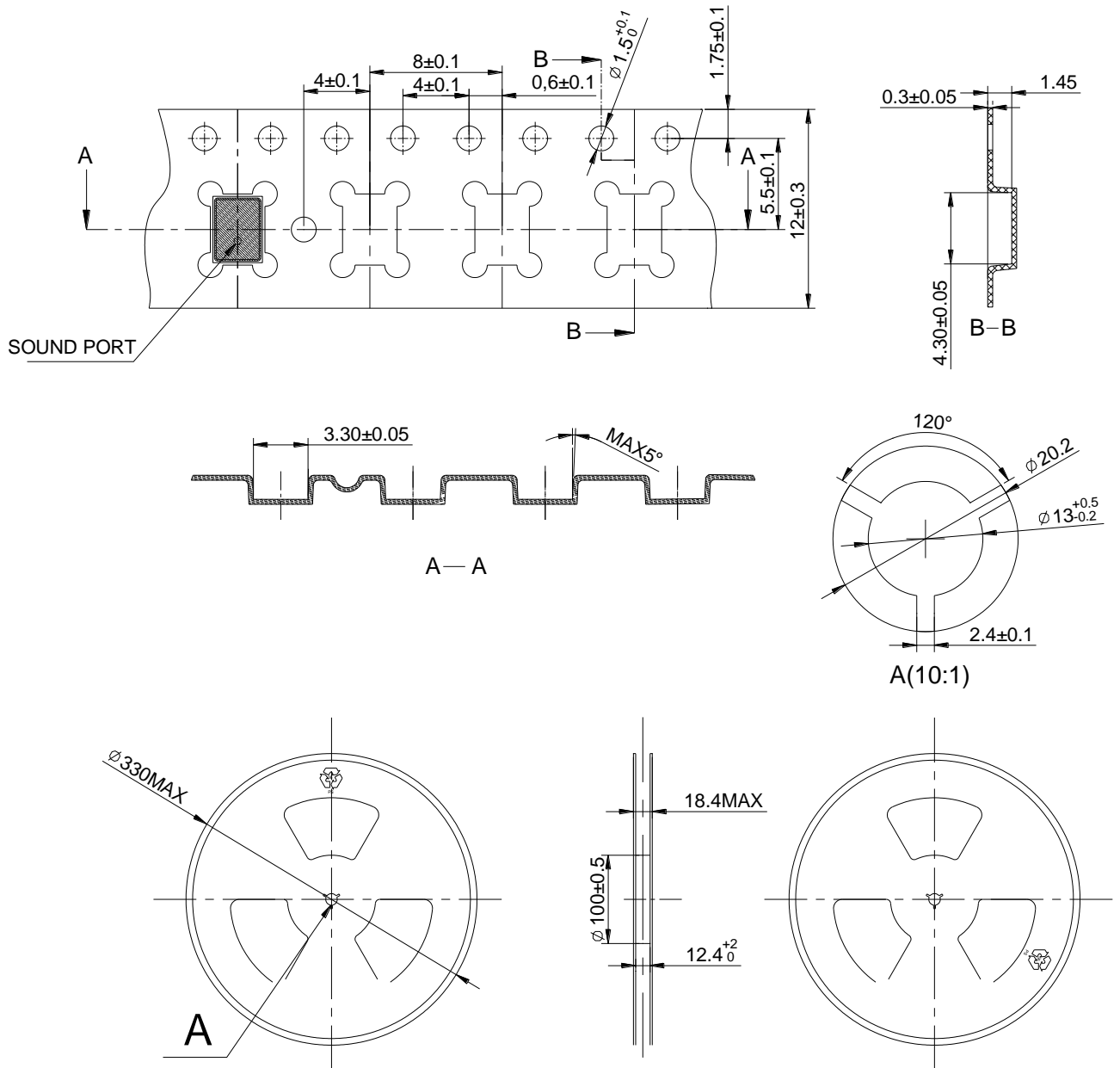

Model Number	Reel Diameter	Quantity Per Reel
WBC4030AB38B1A10	13"	4500

Notes:

- Dimensions are in millimeters unless otherwise specified.
- Vacuum pickup only in the pick area indicated in Mechanical Specifications.
- Tape & reel per EIA-481.
- Labels applied directly to reel and external package.

Referenced Reflow Profile

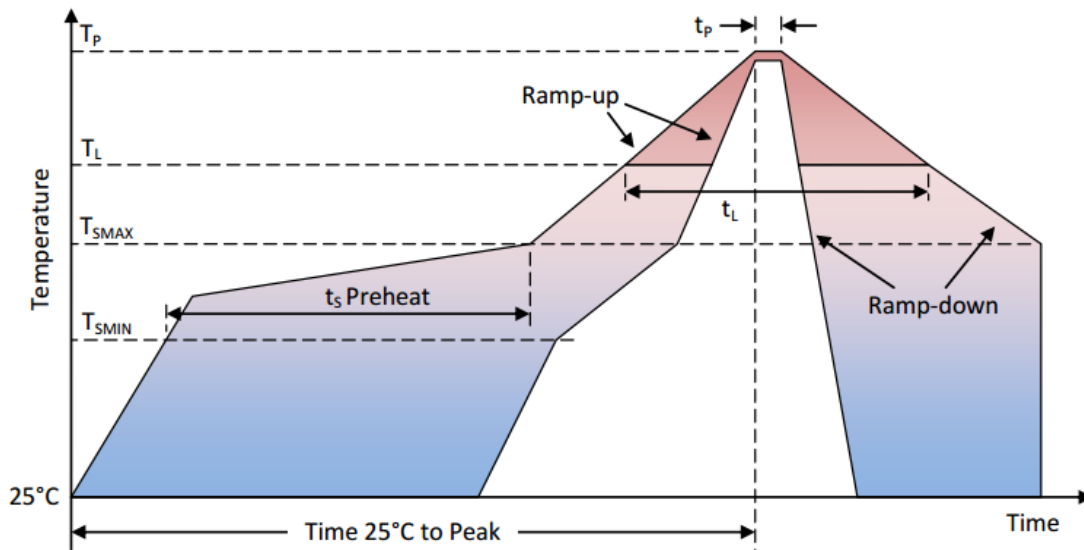

Profile Feature	Pb-Free
Average Ramp-up rate (T_{SMAX} to T_P)	3°C/second max.
Preheat <ul style="list-style-type: none"> • Temperature Min (T_{SMIN}) • Temperature Max (T_{SMAX}) • Time (T_{SMIN} to T_{SMAX}) (t_s) 	150°C 200°C 60-180 seconds
Time maintained above: <ul style="list-style-type: none"> • Temperature (T_L) • Time (t_L) 	217°C 60-150 seconds
Peak Temperature (T_P)	260°C
Time within 5°C of actual Peak Temperature (t_p)	20-40 seconds
Ramp-down rate (T_P to T_{SMAX})	6°C/second max
Time 25°C to Peak Temperature	8 minutes max

Note:

All temperatures refer to topside of the package, measured on the package body surface.

Additional Notes

(A) Maximum of 3 reflow cycles is recommended.

(B) In order to minimize device damage:

- Do not board wash or clean after the reflow process.
- Do not brush board with or without solvents after the reflow process.
- Do not directly expose to ultrasonic processing, welding, or cleaning.
- Do not insert any object in port hole of device at any time.
- Do not apply over 30 psi of air pressure into the port hole.
- Do not pull a vacuum over port hole of the microphone.
- Do not apply a vacuum when repacking into sealed bags at a rate faster than 0.5 atm/sec.

Materials Statement

Meets the requirements of the European RoHS and Halogen-Free.

Reliability Specifications

Test	Description
Thermal Shock	100 cycles air-to-air thermal shock from -40°C to +125°C with 15 minute soaks.
High Temperature Storage	1000 hours at +105°C environment
Low Temperature Storage	1000 hours at -40°C environment
High Temperature Bias	1000 hours at +105°C under bias.
Low Temperature Bias	1000 hours at -40°C under bias.
Temperature / Humidity Bias	1000 hours at +85°C /85% R.H.
Vibration	4 cycles of 20 to 2,000 Hz sinusoidal sweep with 20g peak acceleration lasting 12 minutes in X, Y, and Z directions.
ESD-HBM	3 discharges of ±3 kV direct contact to I/O pins.
ESD-LID/GND	3 discharges of ±8 kV direct contact to lid while unit is grounded.
ESD-MM	3 discharges of ±250V direct contact to I/O pins.
Reflow	5 reflow cycles with peak temperature of +260°C
Mechanical Shock	3 pulses of 10,000g in the X, Y, and Z direction
Drop Test	To be no interference in operation after dropped to marble or 1.0cm steel plate 18 times from 1.5 meter height.

Note:

After reliability tests are performed, the sensitivity of the microphones shall not deviate more than 3 dB from its initial value.