

WBC3526DT26TJ0

Top port digital silicon Microphone

Descriptions

WBC3526DT26TJ0 is a Silicon Microphone with digital output and top inlet for sound input. It consists of a MEMS sensor and an encoder IC. It converts sensor analog output signal into 1-bit digital PDM data. The digital output format eliminates AC coupling capacitor, reduces RF noise coupling and eases PCB layout requirement.

WBC3526DT26TJ0 is a cost-effective alternative to traditional electret condenser microphone (ECM). Provided on tap-and-reel, it is ideally suited for high volume applications. And it can be processed directly to customer's PCB using standard automatic pick-and-place equipment and surface mounted via standard solder reflow equipment.

WBC3526DT26TJ0 can be used to implement the array microphones. Speech quality can be significantly improved by combining two microphones.

The WBC3526DT26TJ0 is manufactured in a compact 3.50mm*2.65mm*0.98mm, 6-pin package.

Features

- PDM Output
- High SNR
- Ultra-Stable Performance
- Standard SMD Reflow
- Omnidirectional

Applications

- Smart phones
- Smart speakers/TV
- ANC-TWS/Headset
- Portable communication device
- Notebook and desktop
- Digital still cameras



Product appearance

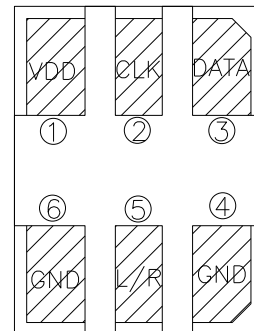

Pin configuration (Bottom view)

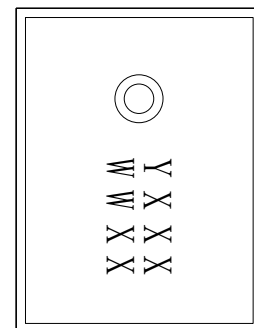

Marking (Top view)

Y = Year code
 WW = Week code
 X X X = Batch code

Order information

Device	Package(mm)	Shipping
WBC3526DT26TJ0-6/TR	3.50*2.65*0.98	5000/Reel&Tape

Absolute Maximum Ratings

Parameter	Maximum Ratings	Unit
Power supply voltage	6.5	V
Operation temperature range	-40~85	°C
Storage temperature range	-40~125	°C

Stresses at the maximum ratings shown in Table 1 may cause permanent damage to the device. These are stress ratings only at which the device may not function when an operation at these or any other condition beyond those specified under “Electro-Acoustic Specifications”.

Acoustic & Electrical Specifications

Normal Mode Electrical Specifications

Test condition: +25±2°C, 60%~70% RH, 86~106Kpa, F_{CLK}=2.4MHz, V_{DD}=1.8V, no load, unless otherwise noted.

Symbol	Description	Min.	Typ.	Max.	Units
F _{CLK}	Clock Frequency	1.3	2.4	4.8	MHz
I _{DD}	Supply Current ¹		770	900	uA
S	Sensitivity ³ , 94dB SPL@1KHz	-27	-26	-25	dBFS ²
ΔS	Sensitivity drop	<0.5			dBFS
SNR	20-20KHz Bandwidth, A-weighted		64		dB(A)
THD	94dB SPL@1KHz		0.15	0.5	%
	118dB SPL@1KHz		1		%
AOP	10%THD@1KHz		120		dB SPL
PSR	Measured with 217Hz, 100mVpp square wave		-90	-80	dBFS
PSRR	Measured with 1KHz, 200mVpp sinewave		60		dBFS

Low Power Mode Electrical Specifications

Test condition: +25±2°C, 60%~70% RH, 86~106Kpa, F_{CLK}=768KHz, V_{DD}=1.8V, no load, unless otherwise noted.

Symbol	Description	Min.	Typ.	Max.	Units
F _{CLK}	Clock Frequency	150	768	900	KHz
I _{DD}	Supply Current		340	450	uA

S	Sensitivity, 94dB SPL@1KHz	-27	-26	-25	dBFS
ΔS	Sensitivity drop	<0.5			dBFS
SNR	20Hz~8KHz Bandwidth, A-weighted		62		dB(A)
THD	94dB SPL@1KHz		0.15	0.5	%
	118dB SPL@1KHz		1		%
AOP	10%THD@1KHz		120		dB SPL
PSR	Measured with 217Hz, 100mV _{pp} square wave		-90	-80	dBFS
PSRR	Measured with 1KHz,200mV _{pp} sinewave		60		dBFS

Note 1: The current consumption depends on the applied clock frequency and the load on the DATA output.

Note 2: dBFS=20*logA/B, where A is the level of signal, and B is the level that corresponds to full-scale level.

Note 3: Relative to the rms level of a sine wave with positive amplitude equal to 100% 1s density and

Negative amplitude equal to 0% 1s density.

Note 4: Frequency response, sensitivity and current consumption are tested by 100% on product line.

General Electrical Specifications

Test condition: +25±2°C, 60%~70% RH, 86~106Kpa, no load, unless otherwise noted.

Symbol	Description	Min.	Typ.	Max.	Units	
VDD	Supply Voltage	1.62	1.8	3.6	V	
ISLEEP	Power Consumption of Stand By, F _{CLK} <50KHz or CLK OFF		6	50	uA	
FCLK	Clock Frequency			50	KHz	
			150	768	900	KHz
			1.3	2.4	4.8	MHz
Data Format		1/2 Cycle PDM				
Directivity		Omni-directional				
Polarity	Increasing sound pressure	Increasing density of 1's				
ISC	Short circuit current, Grounded DATA	1		20	mA	
CLOAD	Load capacitance			100	pF	
Reset time	Time to start up in any mode after VDD has been off for more than 10ms, while CLOCK remained on			20	ms	
Start-up time	Start-up into normal mode or LP mode			20	ms	
Mode-switch time	Mode-switch Normal mode to LP mode or LP mode to Normal mode			20	ms	

Microphone State Diagram

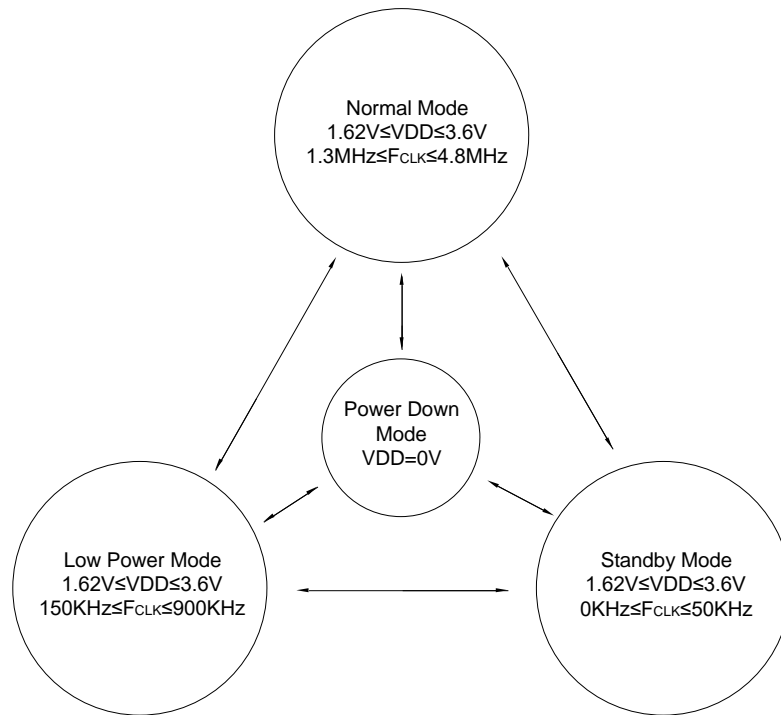

Frequency Response Curve

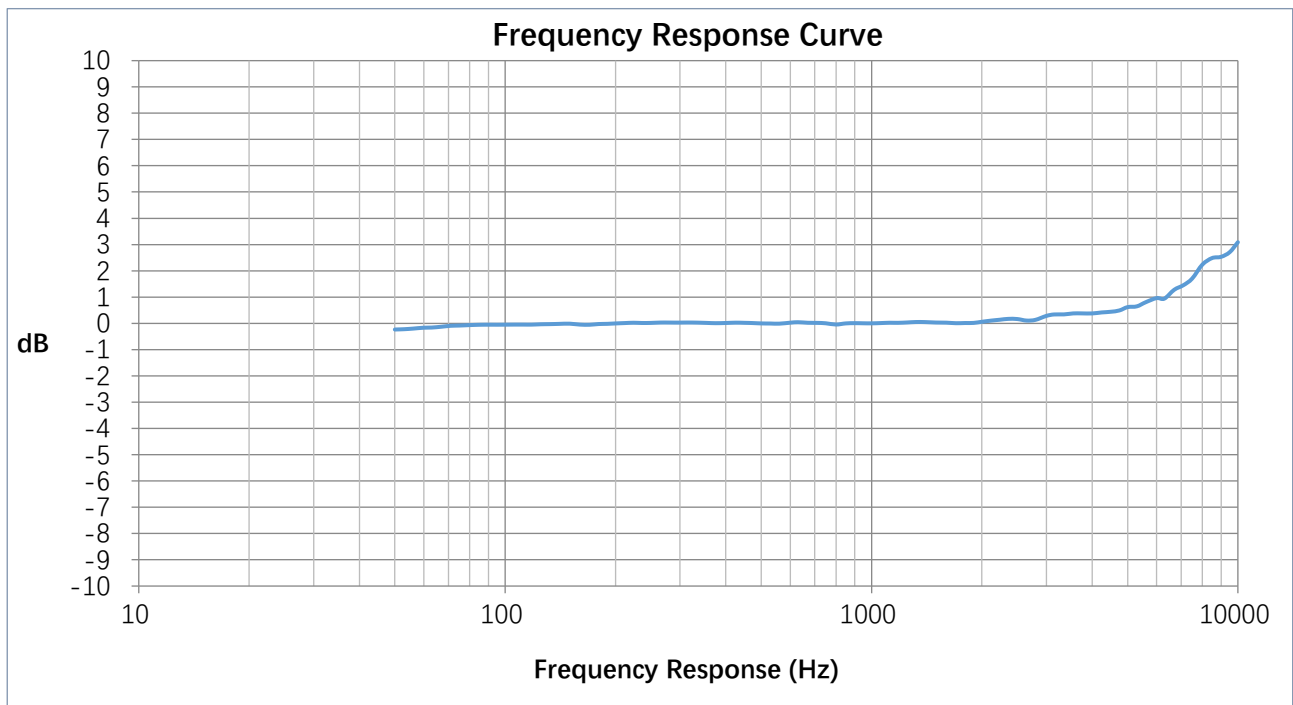

Application Information

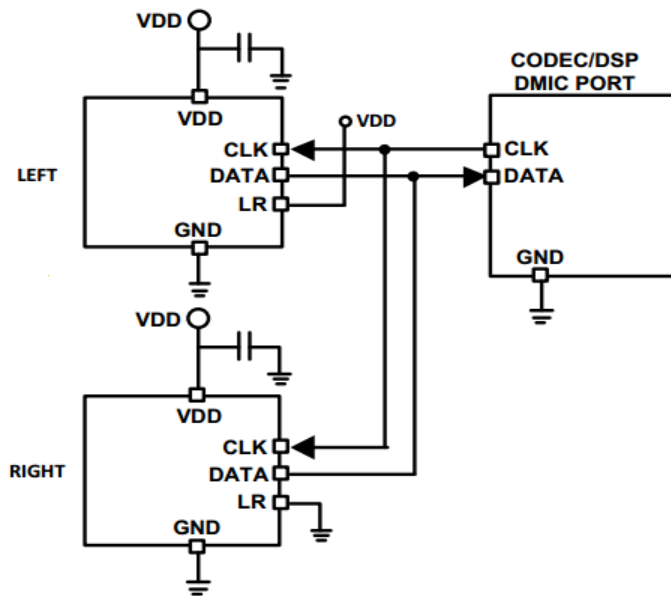

Microphone	SELECT	Asserts DATA On	Latch DATA On
Mic (High)	V _{DD}	Rising Clock Edge	Falling Clock Edge
Mic (Low)	GND	Falling Clock Edge	Rising Clock Edge

Note:

- All GND pins must be connected to ground.
- Capacitors near the microphone should not contain Class 2 dielectrics.

Clock Timing Diagram

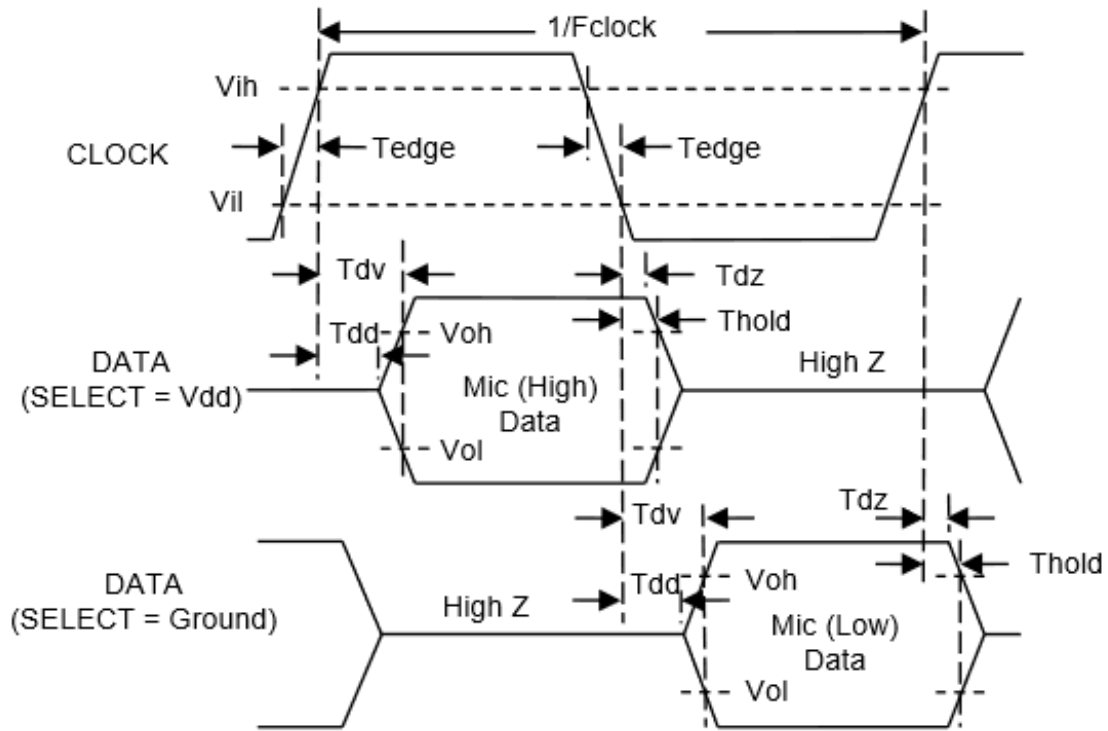

Timing Characteristics

Parameter	Symbol	Min.	Typ.	Max.	Unit	Note
Clock duty cycle		40	50	60	%	
Operation Voltage	V_{DD}	1.62		3.6	V	
Input Logic Low Level	V_{IL}	-0.3		$0.35 \times V_{DD}$	V	
Input Logic High Level	V_{IH}	$0.65 \times V_{DD}$		$V_{DD} + 0.3$	V	
Output Logic Low Level	V_{OL}			0.45	V	
Output Logic High Level	V_{OH}	$V_{DD} - 0.45$			V	
Clock rise time	t_{CR}			6	ns	35%~65%
Clock fall time	t_{CF}			6	ns	65%~35%
Delay time for data valid	t_{dv}	40		100	ns	Delay time from clock edge(0.50 x VDD) to data valid(V_{OL} or > V_{OH})
Delay time for data driven	t_{dd}	25		50	ns	Delay time from clock edge (50% VDD) to data driven.
Delay time for data high Z	t_{HZ}	5		20	ns	Delay time from clock edge(50% VDD) to data

Mechanical Specifications

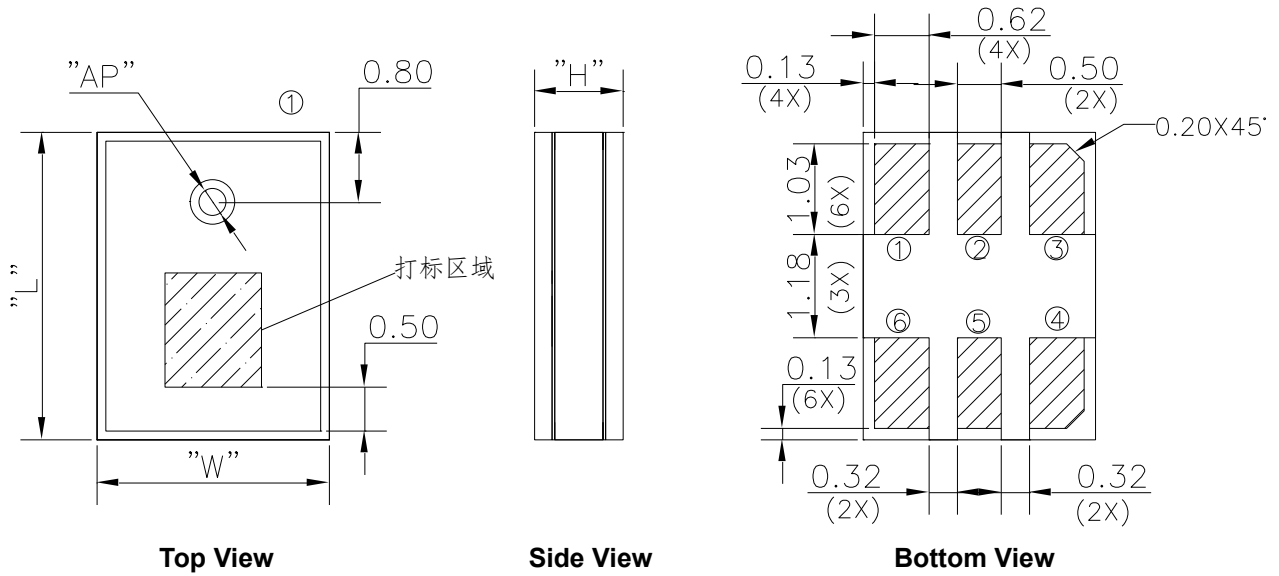

Item	Dimension	Tolerance
Length(L)	3.50	±0.10
Width(W)	2.65	±0.10
Height(H)	0.98	±0.10
Acoustic Port (AP)	Ø0.325	±0.05

Pin#	Pin Name	Description
1	VDD	Power Supply
2	CLK	Clock input
3	DATA	PDM Output
4,6	GND	Ground
5	L/R	Lo/Hi (L/R) Select This pin is internally pulled low but should not be left floating.

Notes:

- Dimensions are in millimeters unless otherwise specified.
- Tolerance is ±0.10mm unless otherwise specified.
- Pick Area only extends to 0.25 mm of any edge or hole unless otherwise specified.
- Suggestion to use the same date code microphone in one array microphone module.

Example Land Pattern

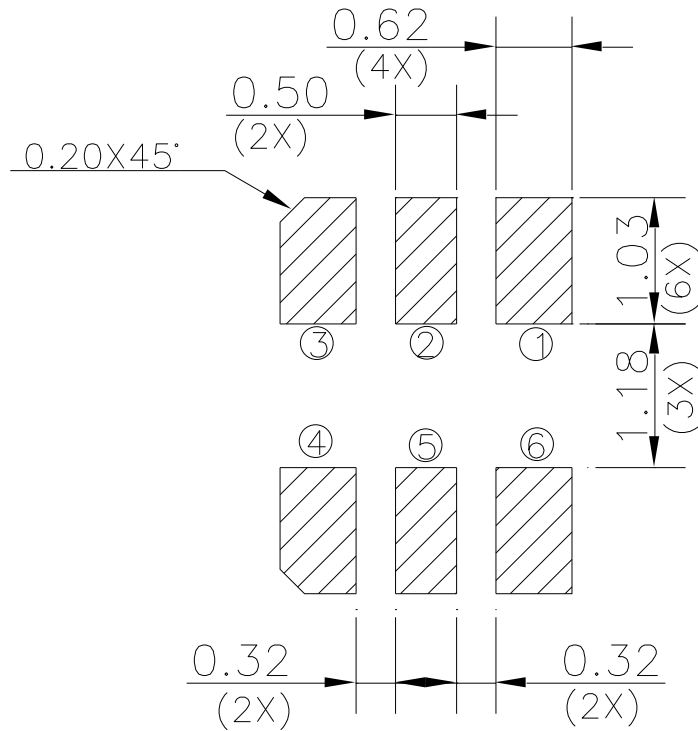

Example Solder Stencil Pattern

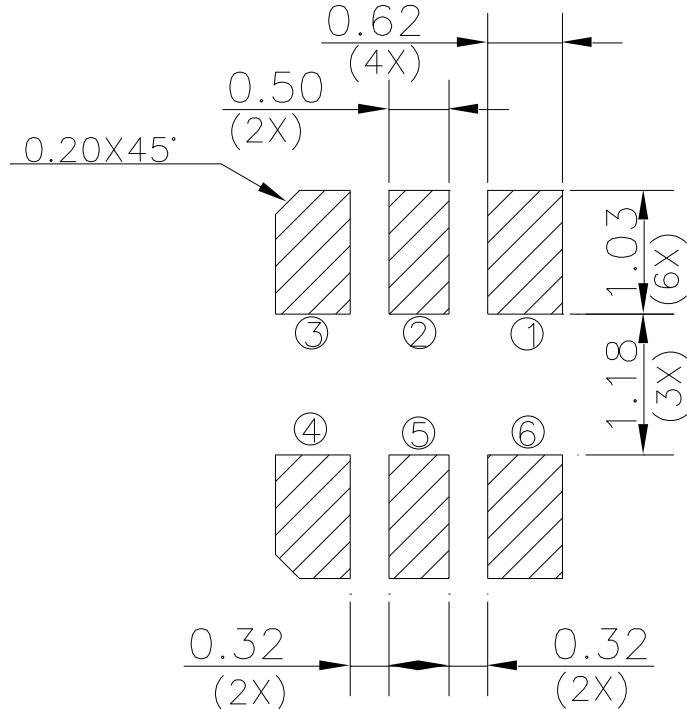

Notes: Dimensions are in millimeters unless otherwise specified.
Further optimizations based on application should be performed.

Packaging & Marking Detail

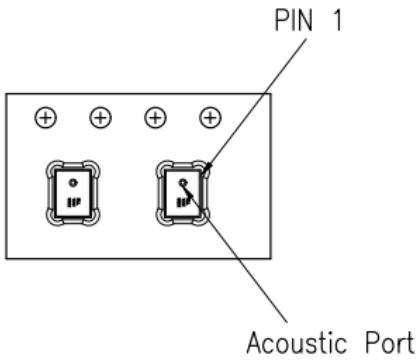
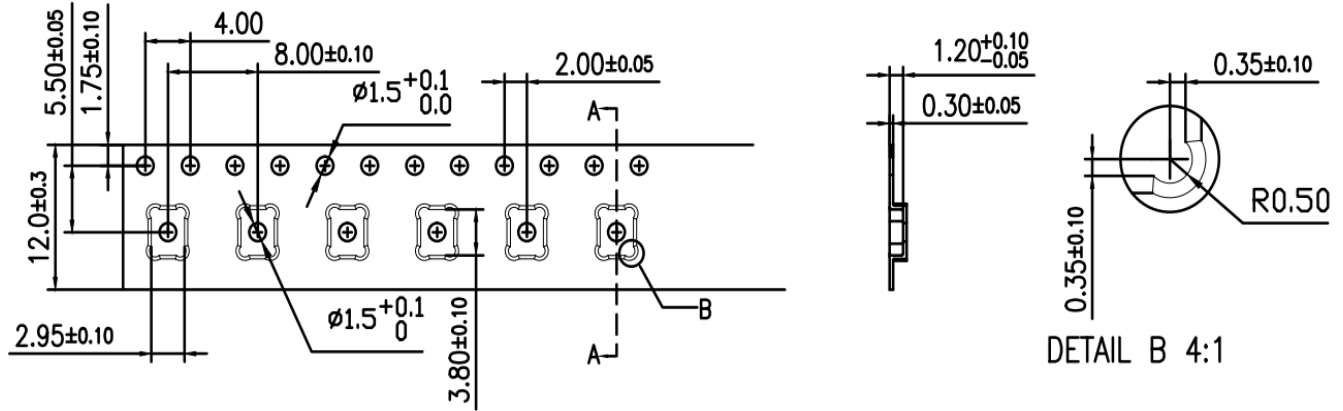

Model Number	Reel Diameter	Quantity Per Reel
WBC3526DT26TJ0	13"	5,000

Notes:

- Dimensions are in millimeters unless otherwise specified.
- Vacuum pickup only in the pick area indicated in Mechanical Specifications.
- Tape & reel per EIA-481.
- Labels applied directly to reel and external package.

Referenced Reflow Profile

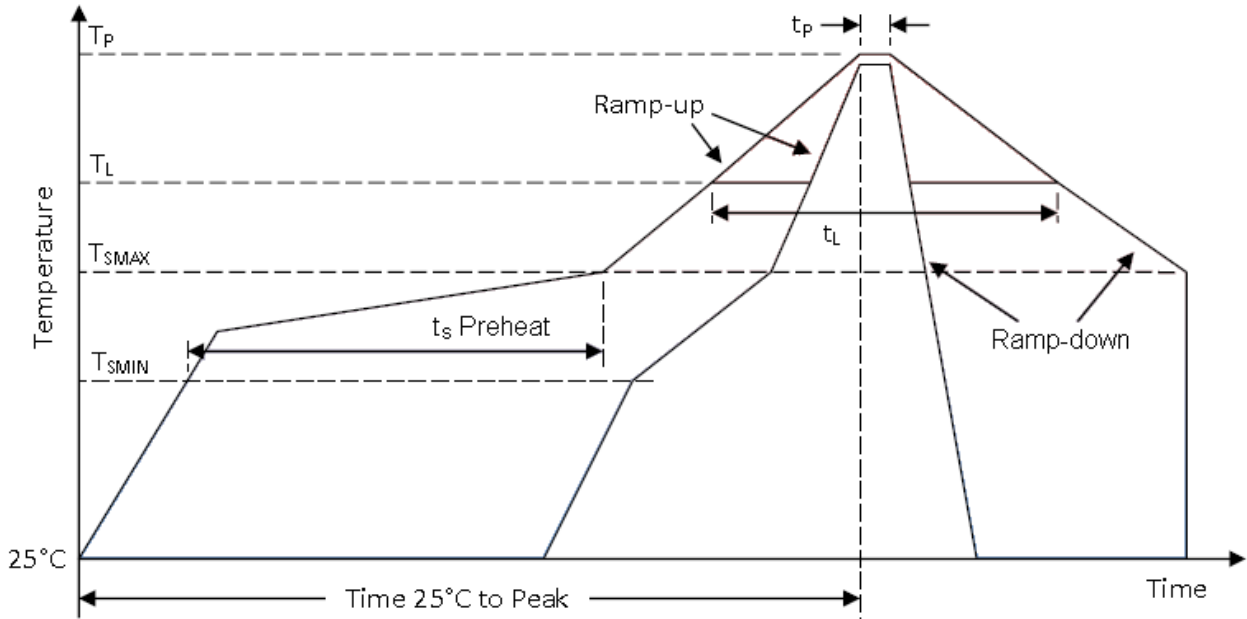

Profile Feature	Pb-Free
Average Ramp-up rate (T_{SMAX} to T_P)	3°C/second max.
Preheat <ul style="list-style-type: none"> • Temperature Min (T_{SMIN}) • Temperature Max (T_{SMAX}) • Time (T_{SMIN} to T_{SMAX}) (t_s) 	150°C 200°C 60-180 seconds
Time maintained above: <ul style="list-style-type: none"> • Temperature (T_L) • Time (t_L) 	217°C 60-150 seconds
Peak Temperature (T_P)	260°C
Time within 5°C of actual Peak Temperature (t_p)	20-40 seconds
Ramp-down rate (T_P to T_{SMAX})	6°C/second max
Time 25°C to Peak Temperature	8 minutes max

Note:

All temperatures refer to topside of the package, measured on the package body surface.

Additional Notes

- (A) Maximum of 3 reflow cycles is recommended.
- (B) In order to minimize device damage:
- Do not board wash or clean after the reflow process.
 - Do not brush board with or without solvents after the reflow process.
 - Do not directly expose to ultrasonic processing, welding, or cleaning.
 - Do not insert any object in port hole of device at any time.
 - Do not apply over 30 psi of air pressure into the port hole.
 - Do not pull a vacuum over port hole of the microphone.
 - Do not apply a vacuum when repacking into sealed bags at a rate faster than 0.5 atm/sec.

Materials Statement

Meets the requirements of the European RoHS and Halogen-Free.

Reliability Specifications

Test	Description
Thermal Shock	100 cycles air-to-air thermal shock from -40°C to +125°C with 15 minute soaks. (IEC 68-2-4)
High Temperature Storage	1000 hours at +105°C environment. (IEC 68-2-2 Test Ba)
Low Temperature Storage	1000 hours at -40°C environment. (IEC 68-2-2 Test Aa)
High Temperature Bias	1000 hours at +105°C under bias. (IEC 68-2-2 Test Ba)
Low Temperature Bias	1000 hours at -40°C under bias. (IEC 68-2-2 Test Aa)
Temperature / Humidity Bias	1000 hours at +85°C /85% R.H. under bias. (JESD22-A101A-B)
Vibration	4 cycles of 20 to 2,000 Hz sinusoidal sweep with 20g peak acceleration lasting 12 minutes in X, Y, and Z directions. (Mil-Std-883E, method 2007.2 A)
ESD-HBM	3 discharges of ±3.5kV direct contact to I/O pins. (ESD STM5.2)
ESD-LID/GND	3 discharges of ±8 kV direct contact to lid while unit is grounded. (IEC 61000-4-2)
ESD-MM	3 discharges of ±200V direct contact to I/O pins. (ESD STM5.2)
Reflow	5 reflow cycles with peak temperature of +260°C.
Mechanical Shock	3 pulses of 10000g in the X, Y, and Z direction. (IEC 68-2-27, Test Ea)
Drop Test	To be no interference in operation after dropped to marble or 1.0cm steel plate 18 times from 1.5 meter height.

Note:

After reliability tests are performed, the sensitivity of the microphones shall not deviate more than 3 dB from its initial value. (The measurement to be done after 2 hours of conditioning at 20±2 °C, R.H 60%~70%)