

WBC2718AT42F1S0

Top port analog silicon Microphone

Descriptions

The WBC2718AT42F1S0 is a miniature, high performance, low power, top port silicon microphone.

The WBC2718AT42F1S0 consists of an acoustic sensor, a low noise input buffer, and an output amplifier.

These devices are suitable for portable electronic devices where excellent wideband audio performance.

The WBC2718AT42F1S0 is manufactured in a compact 2.75mm*1.85mm*0.90mm, 4-pin package.

Features

- Small package
- Low current
- Ultra-Stable Performance
- Standard SMD Reflow
- Omnidirectional

Applications

- Cellphones
- Smart phones
- Headset
- TWS
- Digital still cameras
- Portable music recorders

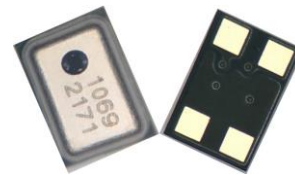

Product appearance

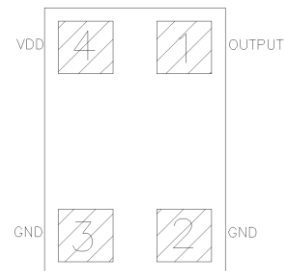

Pin configuration (Bottom view)

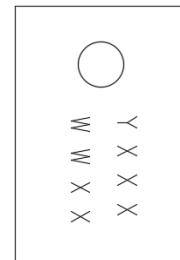

Marking (Top view)

Y = Year code

WW = Week code

X X X = Batch code

Order information

Device	Package	Shipping
WBC2718AT42F1S0-4/T	R2.75*1.85*0.90	5000/Reel&Tape

Absolute Maximum Ratings

Parameter	Absolute Maximum Rating	Units
Supply voltage	4.2	V
Operation temperature range	-40~85	°C
Storage temperature range	-40 to +100	°C

Stresses at the maximum ratings shown in Table 1 may cause permanent damage to the device. These are stress ratings only at which the device may not function when an operation at these or any other condition beyond those specified under “Electro-Acoustic Specifications”.

Acoustic & Electrical Specifications

Test condition: +25±2°C, 60%~70% RH, 86~106Kpa, Vdd=2.75V, no load, unless otherwise specified.

Parameter	Symbol	Conditions	Min	Typ	Max	Units
Supply Voltage	VDD		1.6	-	3.6	V
Supply Current	IDD		-	135	200	uA
Sensitivity	S	94dB SPL @1kHz	-43	-42	-41	dBv
Signal to Noise Ratio	SNR	94dB SPL @1kHz, A-weighted	-	54	-	dB(A)
Total Harmonic Distortion	THD	94dB SPL @1kHz, S=Typ	-	0.2	-	%
Acoustic Overload Point	AOP	10%THD @1kHz	-	126	-	dB SPL
Power Supply Rejection	PSR	100mVpp 7/8 duty cycle rectangular wave @217Hz, A-weight, 20kHz BW	-	-101	-	dBv
DC Output		-	-	0.85	-	V
Output impedance	ZOUT	@1kHz	-	-	400	Ω
Directivity			Omnidirectional			

Note: Frequency response, sensitivity and current consumption are tested by 100% on product line.

Frequency Response Curve

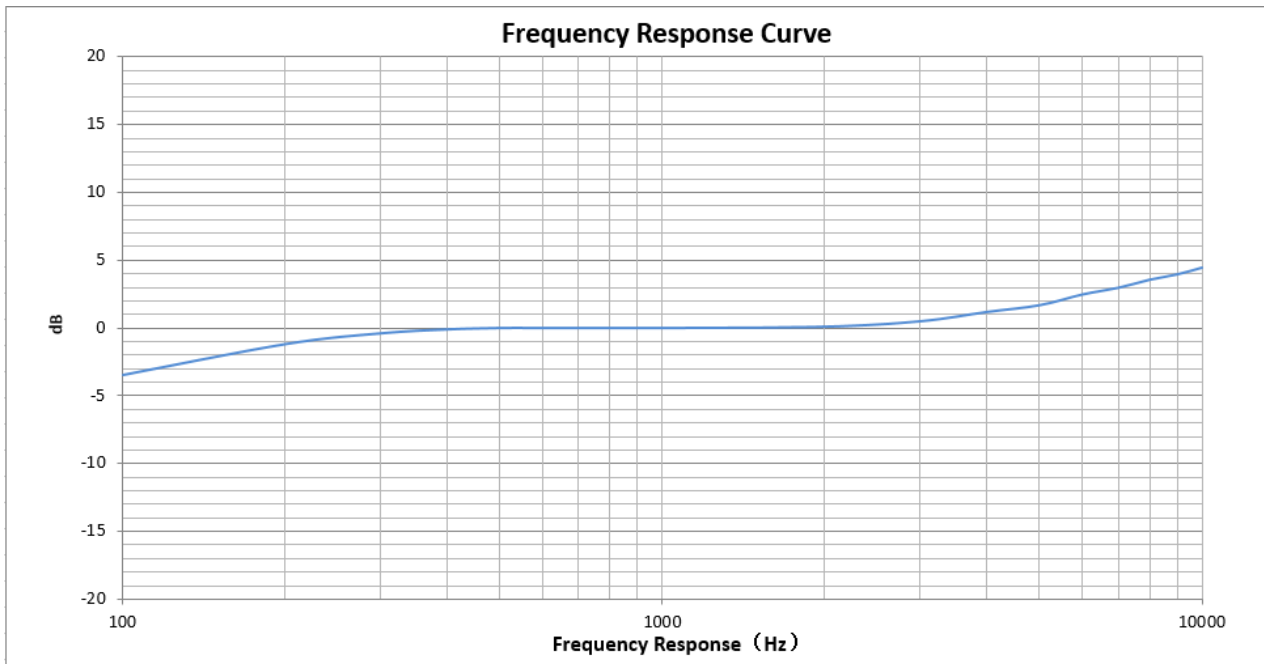

Application Informations

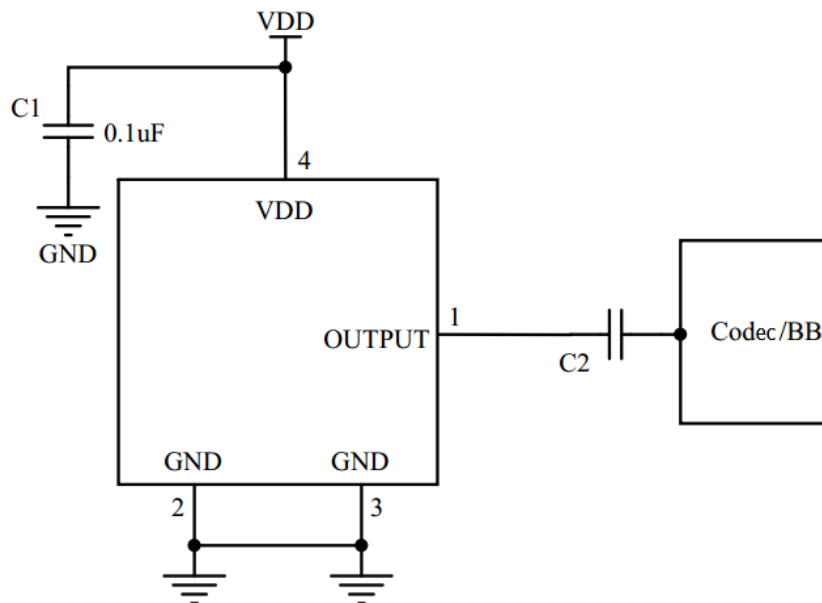

Note:

- All GND pins must be connected to ground.
- Capacitors near the microphone should not contain Class 2 dielectrics.

Mechanical Specification

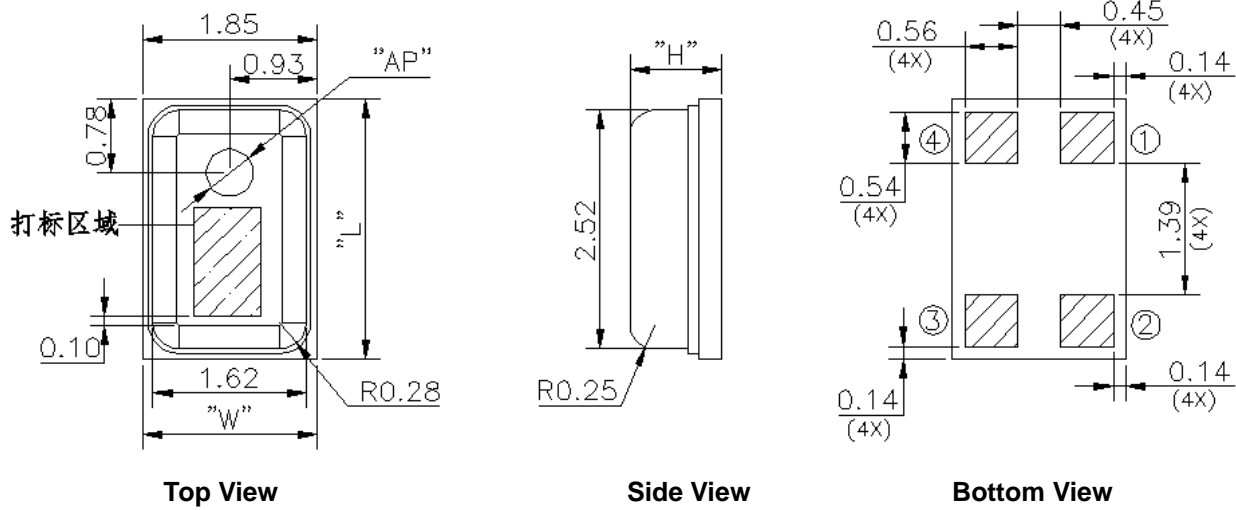

Item	Dimension	Tolerance
Length(L)	2.75	±0.10
Width(W)	1.85	±0.10
Height(H)	0.90	±0.10
Acoustic Port (AP)	Ø0.5	±0.05

Pin#	Pin Name	Description
1	OUTPUT	Output Signal
2	GND	GND
3	GND	GND
4	VDD	Power Supply

Notes:

- Dimensions are in millimeters unless otherwise specified.
- Tolerance is ±0.10mm unless otherwise specified.

Example Land Pattern

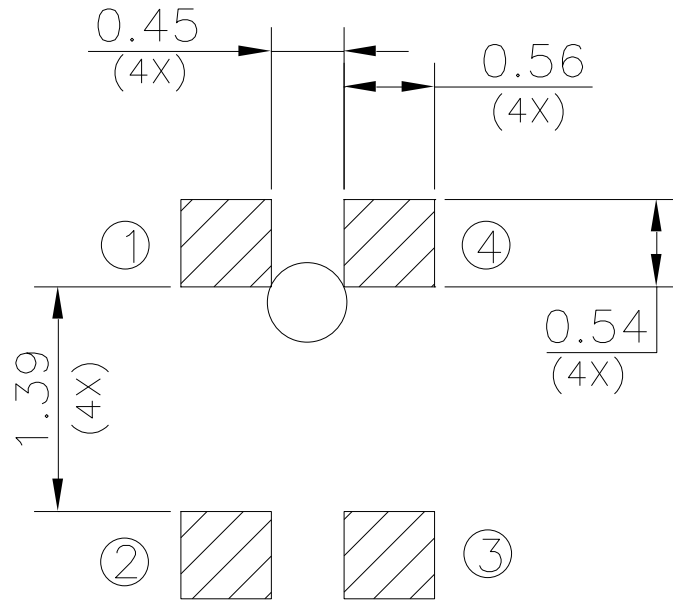

Example Solder Stencil Pattern

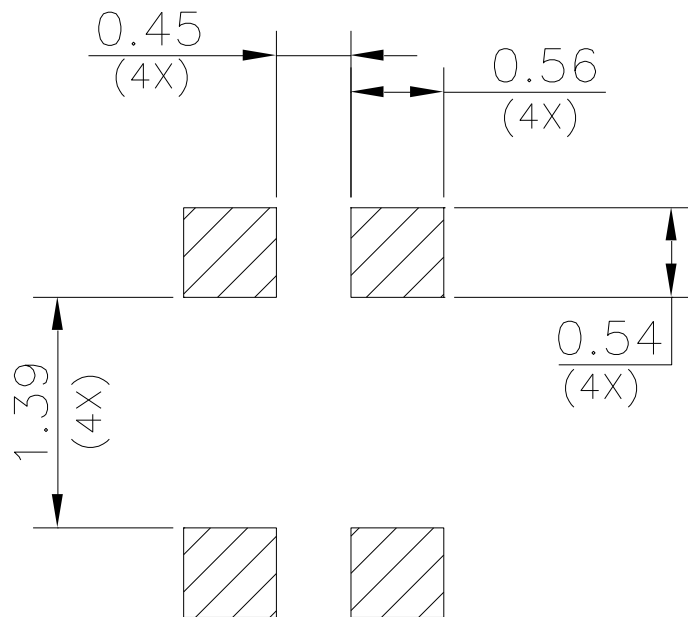

Packaging & Marking Detail

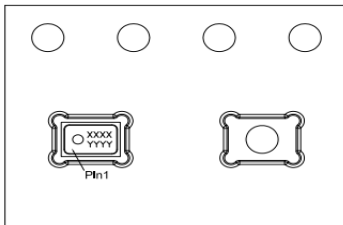
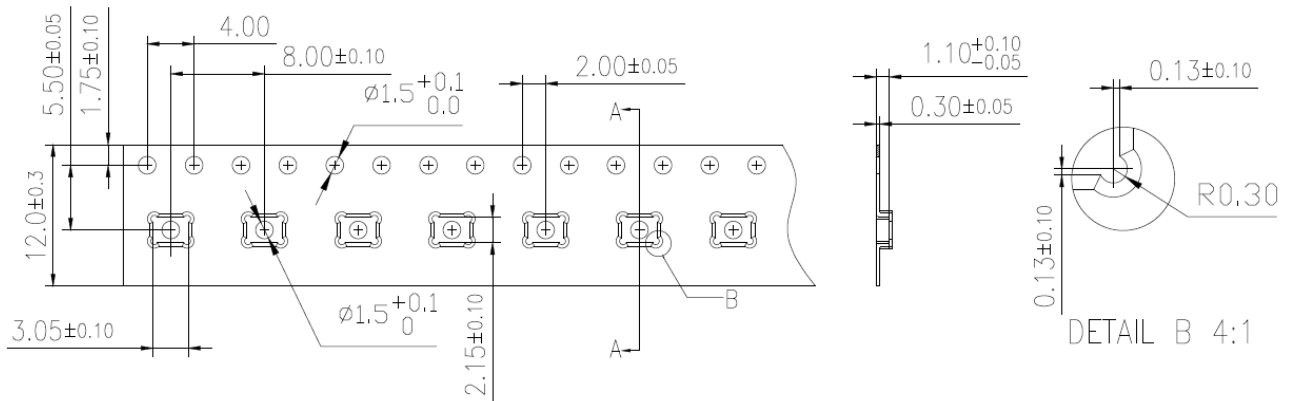

Model Number	Reel Diameter	Quantity Per Reel
WBC2718AT42F1S0	13"	5,000

Notes:

- Dimensions are in millimeters unless otherwise specified.
- Vacuum pickup only in the pick area indicated in Mechanical Specifications.
- Tape & reel per EIA-481.
- Labels applied directly to reel and external package.

Referenced Reflow Profile

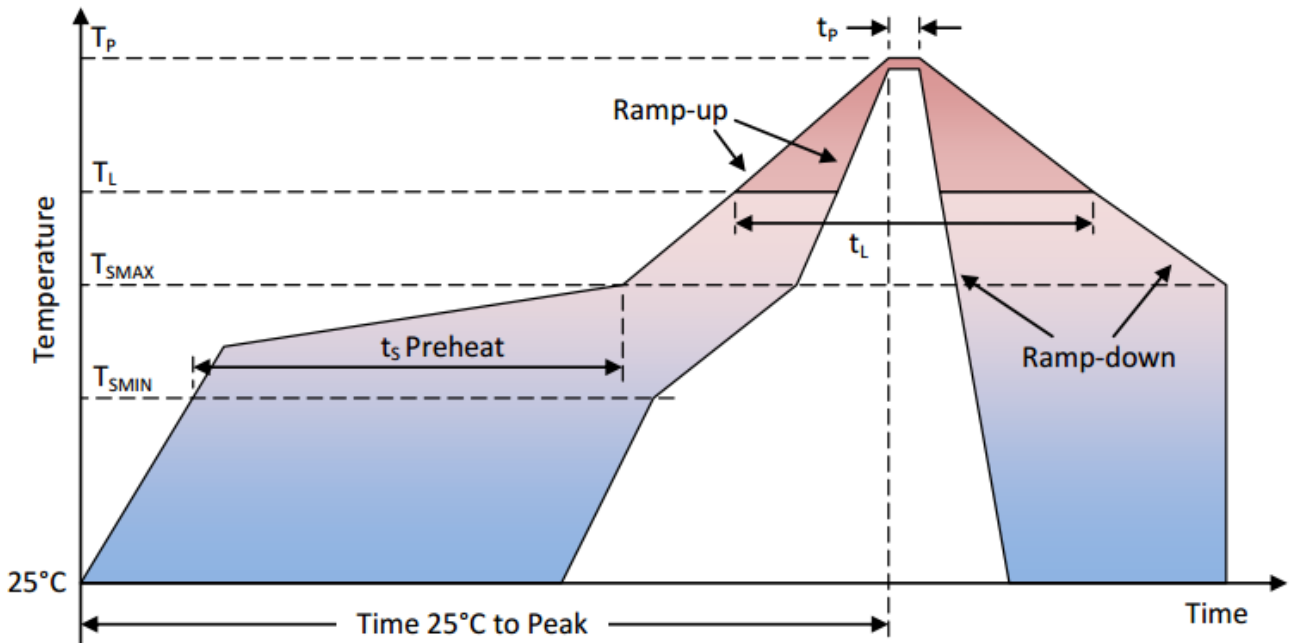

Profile Feature	Pb-Free
Average Ramp-up rate (T_{SMAX} to T_P)	3°C/second max.
Preheat <ul style="list-style-type: none"> • Temperature Min (T_{SMIN}) • Temperature Max (T_{SMAX}) • Time (T_{SMIN} to T_{SMAX}) (t_s) 	150°C 200°C 60-180 seconds
Time maintained above: <ul style="list-style-type: none"> • Temperature (T_L) • Time (t_L) 	217°C 60-150 seconds
Peak Temperature (T_P)	260°C
Time within 5°C of actual Peak Temperature (t_p)	20-40 seconds
Ramp-down rate (T_P to T_{SMAX})	6°C/second max
Time 25°C to Peak Temperature	8 minutes max

Note:

All temperatures refer to topside of the package, measured on the package body surface.

Additional Notes

(A) Maximum of 3 reflow cycles is recommended.

(B) In order to minimize device damage:

- Do not board wash or clean after the reflow process.
- Do not brush board with or without solvents after the reflow process.
- Do not directly expose to ultrasonic processing, welding, or cleaning.
- Do not insert any object in port hole of device at any time.
- Do not apply over 30 psi of air pressure into the port hole.
- Do not pull a vacuum over port hole of the microphone.
- Do not apply a vacuum when repacking into sealed bags at a rate faster than 0.5 atm/sec.

Materials Statement

Meets the requirements of the European RoHS and Halogen-Free.

Reliability Specifications

Test	Description
Thermal Shock	100 cycles air-to-air thermal shock from -40°C to +125°C with 15 minute soaks.
High Temperature Storage	1000 hours at +105°C environment
Low Temperature Storage	1000 hours at -40°C environment
High Temperature Bias	1000 hours at +105°C under bias.
Low Temperature Bias	1000 hours at -40°C under bias.
Temperature / Humidity Bias	1000 hours at +85°C /85% R.H.
Vibration	4 cycles of 20 to 2,000 Hz sinusoidal sweep with 20g peak acceleration lasting 12 minutes in X, Y, and Z directions.
ESD-HBM	3 discharges of ±2 kV direct contact to I/O pins.
ESD-LID/GND	3 discharges of ±8 kV direct contact to lid while unit is grounded.
ESD-MM	3 discharges of ±200V direct contact to I/O pins.
Reflow	5 reflow cycles with peak temperature of +260°C
Mechanical Shock	3 pulses of 10,000g in the X, Y, and Z direction
Drop Test	To be no interference in operation after dropped to marble or 1.0cm steel plate 18 times from 1.5 meter height.

Note:

After reliability tests are performed, the sensitivity of the microphones shall not deviate more than 3 dB from its initial value.